

INSTALLATION INSTRUCTIONS FOR ALL MODELS OF WOLO SERIES 3500 PRIORITY 1 WARNING LIGHTS MAGNET MOUNT

Your choice of a Wolo warning light is the perfect choice to compliment your vehicle. Wolo's warning lights are manufactured with the finest materials. Each light is tested to meet our high standards before it is packaged, to assure a perfect working light. Our quality workmanship and components are Wolo's assurance of a product that will give years of dependable service.

If you need help using your new Wolo warning lights, our technicians are available to answer your questions, Monday thru Friday, from 9 AM to 4 PM EST at 1-888-550-4676.

MAGNET MOUNTING

IMPORTANT: Vehicle roof construction varies for vehicle as well as driving conditions. The vehicle should never be driven with this warning light magnetically mounted. It is possible that the light could dislodge off the mounting surface and cause injury or damage. Ignoring this warning shall be the sole responsibility of the user and or vehicle owner.

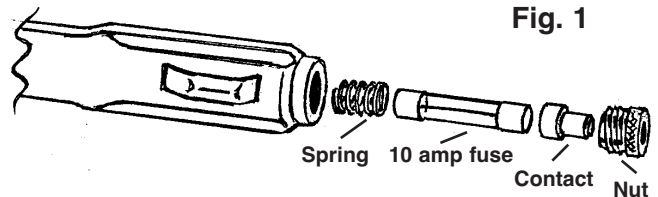

1. The magnets holding power to the mounting surface is dependent upon the following: flatness, condition and finish of surface as well as the thickness of steel surface.
For maximum magnet strength follow the recommendations:
 - A. The vehicles mounting surface should be kept clean and free of wax, dirt, dust and foreign particles.
 - B. The bottom of the magnets rubber cover should be kept clean and free of wax, dirt, dust and foreign particles.
 - C. Always make sure that the mounting surface is flat and that all four (4) magnets are fully secured to the mounting surface.
 - D. Never attempt to secure magnet mount to a vehicle that has a fabric or vinyl covering the mounting surface.
2. Locate the desired location where you wish to mount the warning light. For best results you should make sure the lens is unobstructed so that the light can be seen 360 degrees.

POWERING WARNING LIGHT:

3. To turn on the warning light, simply insert the cigarette lighter plug into the vehicles power socket.
4. To turn off the warning light, remove the cigarette lighter plug from the vehicles power socket.

IMPORTANT: The cigarette light plug has built-in fuse to protect the warning light and the vehicle. If the warning light does not turn on when the plug is inserted into the vehicle power socket, check the fuse built into the power plug by the following method:

The tip of the power plug has a chrome push-in contact which is secured by a nut. Unscrew the nut, pull out the contact and fuse. If the fuse needs to be replaced use a 10 amp fuse. Follow the reverse procedure to re-assemble fuse back into power plug. (See Fig. 1)

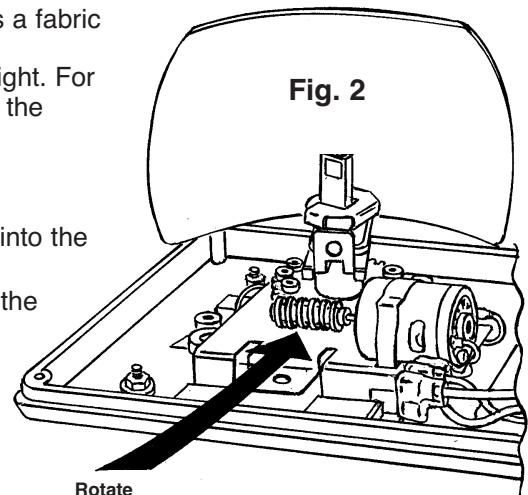

REPLACEMENT BULB

5. **WARNING: A serious injury can result if the bulb is touched when hot. Always allow five (5) minutes for the bulb to cool before removing. Always wear gloves and eye protection when removing the bulb because Halogen bulbs are pressurized and if broken, glass can be projected.**
6. Remove the four screw (one in each corner) holding the lens to the lights base and remove lens
7. Replacement bulb type use only H1/55 watt halogen, 12 volt. Current draw: 9.2 amps.
8. Rotate the reflector by turning the motor shaft with your finger until the C-clip located at the base of the bulb can be easily removed by simply sliding it off. (See Fig. 2). **Please note position of the bulb before removing so you can place the new bulb in the same position.**
9. Remove the C-clip then pull the bulb straight up toward the top of the reflector until there is enough wire extended so that you can hold the terminal at the base of the light. While holding the terminal, pull on the bulb at the metal base and it will separate

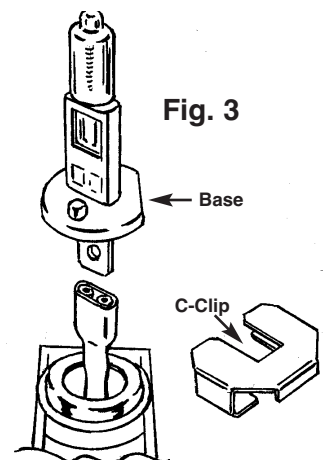

from the terminal. Dispose of the bad bulb out of reach of children and in an environmentally safe manner. (See Fig. 3).

10. Never handle the glass of the new bulb with your fingers, doing such will shorten service life. If by accident you touch the bulb, clean with household glass cleaner.
11. Connect the wire with the female terminal to the base of the new bulb.
12. Position the bulb back into the reflector housing and secure bulb in place with the C-Clamp.
13. Place the lens back onto the lights base and secure with screws removed earlier.

CLEANING

A scratched, dull or dirty lens, reflector or mirror can cause a reduction in brightness of warning light. Never use a caustic or petroleum base cleaner on any surface of the warning light. For best cleaning results, always use household glass cleaner or mild soap with a soft lint free rag. If the lens, reflector or mirror have scratches, or are dull, it is recommended those components be replaced so to ensure maximum brightness of the warning light.

Warranty

Wolo Manufacturing Corporation ("Wolo") warranties to the original purchaser, for three months from the date of purchase, that this product is free from defects in workmanship and materials. If there is such a proven defect, Wolo, at its option, will either repair or replace the item free of charge, if it is returned to Wolo within three months from the date of purchase together with proof of purchase as described below. Wolo reserves the right to inspect any defect prior to settling any warranty claim by repair or replacement. This warranty is limited as above provided and Wolo will not be responsible for fire or other casualty or accident, due to neglect, abuse, abnormal use, modifications, faulty installation of this product, or natural causes.

ANY EXPRESSED WARRANTY NOT PROVIDED HEREIN IS EXCLUDED AND DISCLAIMED. THE IMPLIED WARRANTIES OF MERCHANTABILITY AND OF FITNESS FOR A PARTICULAR PURPOSE ARE EXPRESSLY LIMITED TO A TERM OF THREE (3) MONTHS. UNDER NO CIRCUMSTANCES SHALL WOLO BE LIABLE TO PURCHASER OR ANY OTHER PERSON FOR ANY SPECIAL OR CONSEQUENTIAL DAMAGES, WHETHER ARISING OUT OF BREACH OF WARRANTY OR OTHERWISE.

To obtain warranty service, return the product prepaid, and include the original bill of sale showing the date of purchase. Provide with the return a brief description of the problem with a daytime telephone number. Also, include with the return a check or money order in the amount of \$20.00 to cover return shipping. Mail to:

Wolo Manufacturing Corp.

Attn: Warranty Service
One Saxwood Street
Deer Park, NY 11729
E-mail: tech@wolo-mfg.com

© 2008 Wolo Mfg. Corp
All Rights Reserved.

Revised 8/08