

## INSTALLATION INSTRUCTIONS FOR MODEL 415-MC

The addition of a Wolo horn kit for your motorcycle will provide an extra level of sound. The Wolo name, with more than twenty years experience is your guarantee of a superior horn product. If you need help installing your new Wolo horn, our technicians are available to answer your questions, Monday through Friday from 9 AM to 4 PM EST 1-888-550-HORN (4676).

### COMPRESSOR

1. Install the compressor in a dry location such as luggage compartment, trunk, under seat, etc., safe from engine and exhaust heat. **IMPORTANT:** Compressor must be mounted not further than 8 to 10 inches from trumpets for proper sound.
2. To secure the compressor drill one 5/16" hole. Mount the compressor vertically (air outlet on top). Install the head of the bolt into the slot on the side of the compressor (refer to Fig. A). Secure the compressor to the vehicle using the lock washer/ nut provided.

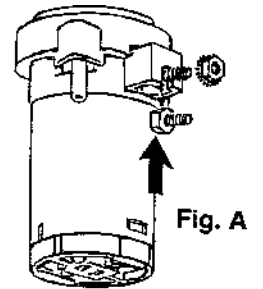

### TRUMPETS

3. Position each trumpet in the location you wish to mount them. Mark and drill a 1/4" hole for each trumpet. Secure each trumpet to motorcycle (refer to Fig. B). Use mounting hardware in order shown – spacer, lock washer/ nut.
4. Cut plastic air tubing to length, and connect trumpets and "Y" connector as shown in Fig. C. Avoid making any kinks or sharp bends in tubing that will restrict airflow and

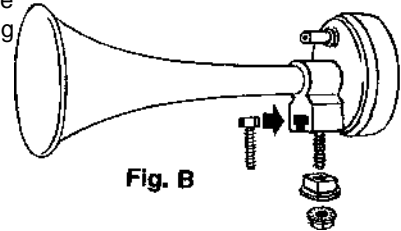

alter the horn's sound.

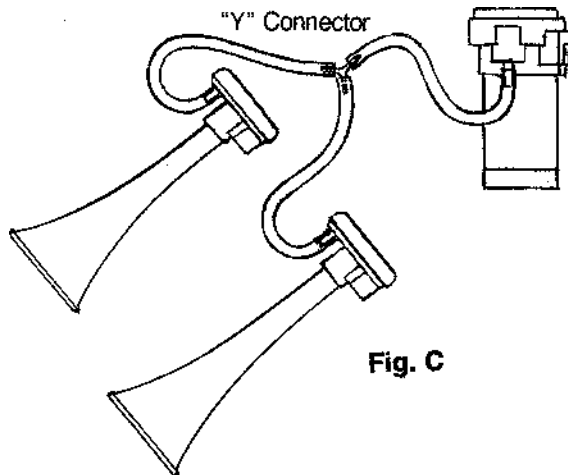

### WIRING

#### 5. ELECTRICAL CONNECTION – USING MOTORCYCLE'S FACTORY HORN SYSTEM (TWO WIRE SYSTEM) Fig. D

- IMPORTANT:** You are required to use the relay supplied with this horn kit to protect the factory horn button switch and wiring. The original factory horn draws less amperage so most motorcycle manufacturers do not provide a relay in the horn circuit.
- Remove the two (2) wires from the factory horn.
- Connect relay terminal 85 to one of the factory horn wires. **Note:** It does not make a difference which wire.
- Connect relay terminal 86 to the other factory horn wire.
- Connect relay terminal 30 to positive (+) 12-volts battery, alternator. Use 16-gauge or heavier wire. A 20-amp fuse should be used as shown in Fig. D to protect the motorcycle.
- Connect relay terminal 87 to the positive terminal at the bottom of the compressor. Use no less than 16 gauge wire.
- Connect the (-) terminal at the bottom of the compressor to ground any clean metal body bolt or the (-) post of the battery. Use no less than 16-gauge wire.

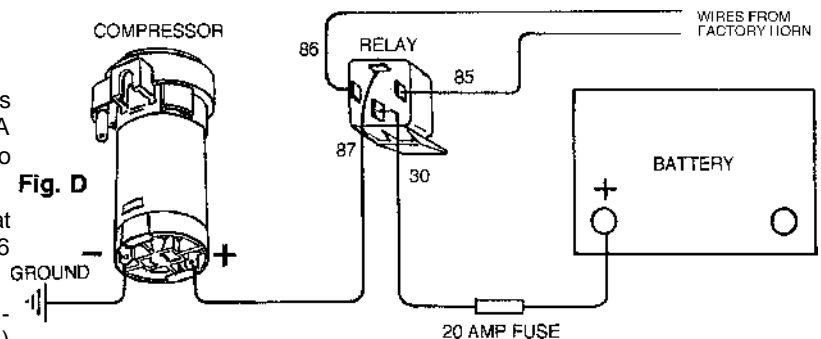

## 6. ELECTRICAL CONNECTION – USING MOTORCYCLE’S FACTORY HORN SYSTEM (ONE WIRE SYSTEM) Fig. E.

- A. **IMPORTANT:** You are required to use the relay supplied with this horn kit to protect the factory horn button switch and wiring. The original factory horn draws less amperage so most motorcycle manufacturers do not provide a relay in the horn circuit.
- B. Remove the wire from the factory horn.
- C. Connect relay terminal 85 to the factory horn wire.
- D. Connect relay terminal 86 to ground any clean metal body bolt or the (-) post of the battery.
- E. Connect relay terminal 30 to positive (+) 12-volts battery, alternator. use 16-gauge or heavier wire. A 20-amp fuse should be used as shown in Fig. E to protect the motorcycle.
- F. Connect relay terminal 87 to the positive terminal at the bottom of the compressor. Use no less than 16 gauge wire.
- G. Connect the (-) terminal at the bottom of the compressor to ground any clean metal body bolt or the (-) post of the battery. Use no less than 16-gauge wire.

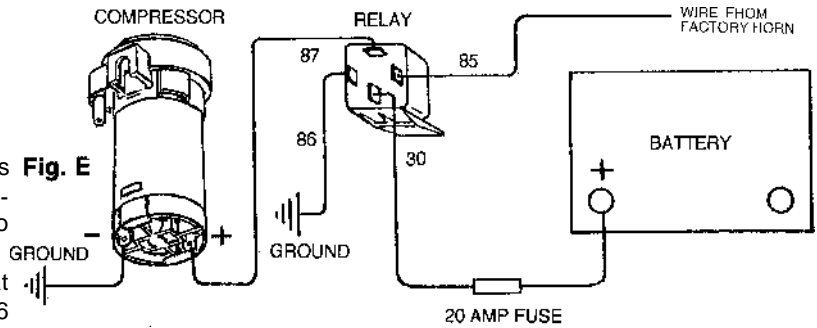

## H. WEATHER PROTECTION COVERS

7. It is recommended that you always use the weather protection covers. They will prevent damage to the trumpet’s diaphragm from rain, bugs, dirt, etc. Assemble the brackets to the cover as shown in Fig. F. below. Do not tighten screw until the cover is placed into position on the front of the trumpet. **Water damage to the horn’s component parts is not covered by our factory warranty.**

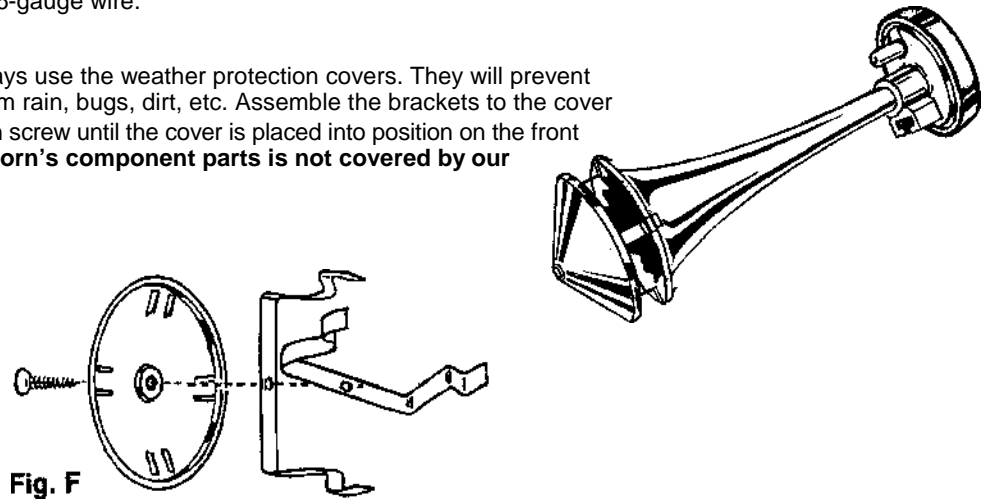

## Warranty

Wolo Manufacturing Corporation (“Wolo”) warranties to the original purchaser, for three months from the date of purchase, that this product is free from defects in workmanship and materials. If there is such a proven defect, Wolo, at its option, will either repair or replace the item free of charge, if it is returned to Wolo within three months from the date of purchase together with proof of purchase as described below. Wolo reserves the right to inspect any defect prior to settling any warranty claim by repair or replacement. This warranty is limited as above provided and Wolo will not be responsible for fire or other casualty or accident, due to neglect, abuse, abnormal use, modifications, faulty installation of this product, or natural causes.

ANY EXPRESSED WARRANTY NOT PROVIDED HEREIN IS EXCLUDED AND DISCLAIMED. THE IMPLIED WARRANTIES OF MERCHANTABILITY AND OF FITNESS FOR A PARTICULAR PURPOSE ARE EXPRESSLY LIMITED TO A TERM OF THREE (3) MONTHS. UNDER NO CIRCUMSTANCES SHALL WOLO BE LIABLE TO PURCHASER OR ANY OTHER PERSON FOR ANY SPECIAL OR CONSEQUENTIAL DAMAGES, WHETHER ARISING OUT OF BREACH OF WARRANTY OR OTHERWISE.

To obtain warranty service, return the product prepaid, and include the original bill of sale showing the date of purchase. Provide with the return a brief description of the problem. Also, include with the return a check or money order in the amount of \$10.00 to cover return shipping. Mail to:



**Wolo Manufacturing Corp.**  
Repair Department  
One Saxwood St.  
Deer Park, NY 11729

If you have questions you can E-mail Wolo's tech department at: tech @wolo-mfg.com