

# INSTALLATION INSTRUCTIONS

## Model PS-1 Replacement High Pressure Switch for On-Board Air System

Your purchase of a Wolo industrial horn is a perfect choice for your equipment for both new and replacement requirements. Wolo's products are manufactured with the finest materials. Each horn is tested to ensure it meets all manufacturing specifications, before it is packaged. If you need help installing this product, our technicians are available to answer your questions, Monday through Friday from 9AM to 4 PM EST by calling 1-888-550-HORN (4676).

### SWITCH INSTALLATION FIG. #1

1. Before installing the PS-1, it is recommended that a visual inspection be made of the tank's or compressors threads to ensure that it is free of rust and corrosion which could cause an air leak when the PS-1 is installed.
2. Install the Model PS-1 to the desired location, (turn PS-1 clockwise to tighten). **Note:** The Model PS-1 has Teflon tape wrapped around its male threads; do not remove the tape it is required to prevent air leaks.

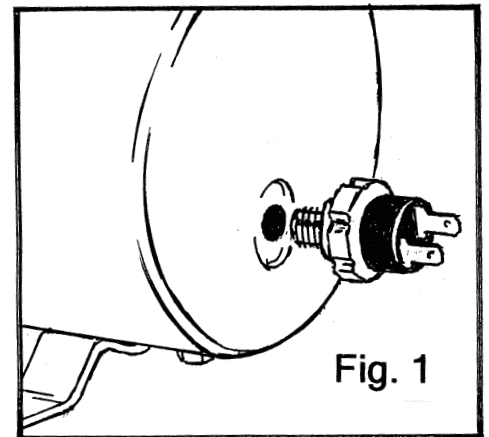

### WIRING SWITCH FIG. #2

3. Connect one of the terminals of the pressure switch to ground; any clean metal body bolt or the (-) negative post of the battery. Always make sure the metal ground surface is free of paint, rust and oxidation.
4. Connect the other terminal of the pressure switch to the compressor's (-) negative wire or post.

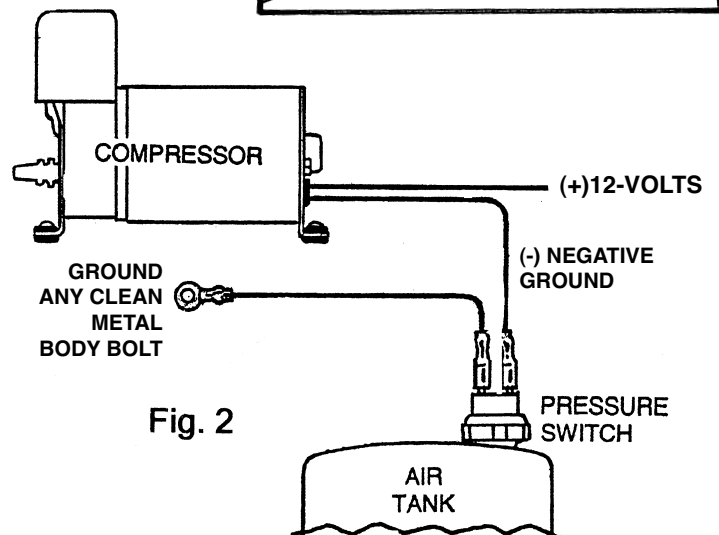

**IMPORTANT:** Always carefully inspect the wires before connecting them to the pressure switch so to ensure that they are clean and free of dirt and corrosion. Make sure all electrical connections are taped and secured

### SPECIFICATIONS

Thread NPT18  
Turn on: 85 PSI  
Turn off: 113 PSI  
3.5amp at 12VDC

## Warranty

Wolo Manufacturing Corporation ("Wolo") warrants to the original purchaser, for three months from the date of purchase, that this product is free from defects in workmanship and materials. If there is such a proven defect, Wolo, at its option, will either repair or replace the item free of charge, if it is returned to Wolo within three months from the date of purchase together with proof of purchase as described below. Wolo reserves the right to inspect any defect prior to settling any warranty claim by repair or replacement. This warranty is limited as above provided and Wolo will not be responsible for fire or other casualty or accident, due to neglect, abuse, abnormal use, modifications, faulty installation of this product, or natural causes.

ANY EXPRESSED WARRANTY NOT PROVIDED HEREIN IS EXCLUDED AND DISCLAIMED. THE IMPLIED WARRANTIES OF MERCHANTABILITY AND OF FITNESS FOR A PARTICULAR PURPOSE ARE EXPRESSLY LIMITED TO A TERM OF THREE (3) MONTHS. UNDER NO CIRCUMSTANCES SHALL WOLO BE LIABLE TO PURCHASER OR ANY OTHER PERSON FOR ANY SPECIAL OR CONSEQUENTIAL DAMAGES, WHETHER ARISING OUT OF BREACH OF WARRANTY OR OTHERWISE.

To obtain warranty service, return the product prepaid, and include the original bill of sale showing the date of purchase. Provide with the return a brief description of the problem. Also, include with the return a check or money order in the amount of \$10.00 to cover return shipping. Mail to:

**Wolo Manufacturing Corp.**

Attn: Warranty Service  
One Saxwood Street  
Deer Park, NY 11729  
E-mail: [tech@wolo-mfg.com](mailto:tech@wolo-mfg.com)